

MOBILE BLOCK ICE MACHINE

TECHNICAL DETAILS AND MANUAL GUIDE



WARNING

USING THIS GUIDE

Please read this user guide carefully and follow all the guidelines in on order to be able to use your device without any problems.

Your installer will be glad to introduce and train you on your device.

IN CASE OF DANGER

- Power off the devices on/off switch.
- Turn off the power from the fuse box.
- Take a picture of the possible dangerous event and observe what is happening in general.
- Contact our help centre.
Tel: +90 (212) 623 22 93 Fax: +90 (212) 623 22 96
- Our help centre will ensure that the nearest authorized service dealer will be in touch.

COMMISSIONING THE DEVICE

- All installation, commissioning and repair work must be carried out authorized expert personnel.
- When working on the device power should be cut of.

OPERATING CONDITIONS OF THE DEVICE

- Dust accumulation should be guarded against.
- Excess humidity should be avoided.
- Measures should be taken against excessive cold and frost.
- Do not operate under direct sunlight and protect the device from the sun.
- Natural and mechanical ventilation should be provided to ensure environmental temperature does not exceed +43°C.

GENERAL INFORMATION

GENERAL

This document contains information on the installation, commissioning, maintenance and repair of the ICE MOULDER brand ice mould units.

During the products installation and usage and maintenance the following instructions should be strictly observed for safety and health reasons.

When the product is purchased, a visual check for damage or missing parts and deficiencies should be carried out and any such occurrence should be reported to the manufacturer within 7 days.

INTRODUCTION TO THE DEVICE

The device described in this document is a mono block ice compacting unit. In other words the unit is in 2 parts that are assembled as a single unit. The commissioning of the device should be carried out by an authorized representative that is familiar with the device characteristics and general safety procedures. In order to prevent accidents, all regulations and rules and safety warnings should be complied with at all times.

The function of the device is to produce ice molds and ice flakes. All other functions are outside of the scope of the agreement between the manufacturer and the user. All damage and loss that may arise as a result of non-authorized modifications is the responsibility of the user and does not bind the manufacturer in any manner.

TRANSPORTATION AND STORAGE

- Carefully inspect for damage to the packaging or to the product.
- Keep the product in its original packaging in a dry and enclosed area until installation or take measures to protect against dirt and environmental effects.
- Protect the device from excessive heat and cold.
- Use a fork lift or a similar lifting device to transport and carry the device.
- Place it on level ground and ensure it's completely level.

BLOCK ICE MACHINE DESCRIPTION

- **Clean & Hygienic**
- **Fast & Easy Useful**
- **Both Flake & Both Block Ice**
- **No Mould & No Glycol**
- **Changeable Ice Dimensions**
- **New Design & New Ice Technology**

Daily Production Range :

- * **3 ton/day = 545 Block 5,5kg.**
- * **5 ton/day = 312 Block 16kg.**
- * **10 ton/day = 625 Block 16kg.**
- * **10 ton/day = 400 Block 25kg.**



Specifications:

- Daily ; 5 ton / 10 ton block ice producing range
- Stainless Steel Construction
- Produces blocks of consistent size, shape, and weight
- Uses flake ice or block
- Blocks stack perfectly in freezers and merchandisers
- Programmable Controller Coordinates
- Machine Cycle Control
- Electrical 380V - 3 phase (standard)
- Hydraulically activated system
- Efficient - only 5 HP electric motor and cooling compressor
- Convenient "maintainability"
- Block ice weight: See Ice Machine Table list
- Block ice size: 15 x 15 x 30 cm. 5,5kg
- Block ice size: 20 x 20 x 50 cm. 16kg.
- Block ice size: 25 x 25 x 50 cm. 25kg.
- One-man operation
- PLC controlled panel
- Oil cooler (optional)

PRESSED BLOCK ICE ADVANTAGES AND WORKING PRINCIPLE:

Our Block Ice Pressing machines have more practical, dynamic and smart design when compared with the others.

You can get ice blocks by completing pressing process in adjusted compression rate by taking ice which leaf ice machine produces in adjusted weight.

You can change its height however you like without changing width and size of block ice. This feature is the most important feature which differentiates our products from other products. In this way, you can produce the same block ice with different capacity ice machines, only production time changes.

- It is completely hygienic; it produces ice without hand contact. It has no hazardous production such as brine, ant-freeze or similar food in old procedures.
- No need to wait. It starts to produce ice continuously within a short time from the moment you switch it on. In old procedure, you need to wait for a period like 12 hours.
- There is no problem like bar. It produces bar and problem-free compressed ices instead of deformed and difficult ice removing bar system.
- You do not need to pour water since it is fully automatic, it takes water automatically in quantity which water is required and it is adjusted.
- Your need is instantly met since it produces ice immediately.
- It enables you to be 2 different ice producers in order to use leaf ice when needed, this is advantage for you.
- It enables you to change size of ice bars easily and therefore it makes you superior other than your rivals and it provided product variety.
- Shape is fully rectangular, since it has no shape like conical it provides an easy stacking and its presentation is better in terms of visual aspect.



DEVICE COMPONENT

- 1- COMPRESSOR
- 2- COMPRESSOR FANS
- 3- CONDENSER
- 4- ELECTRIC CONTROL BOARD
- 5- LOW & HIGH PRESSURE PRESOSTAD
- 6- CONDENSER FAN SPEED CONTROLLER
- 7- PRESSURE MANOMETERS
- 8- MANOMETER STOP VALVE
- 9- LIQUID LINE VALVES
- 10- GAS CHARGE VALVE
- 11- DRYER FILTER
- 12- OIL PRESOSTAD
- 13- SIGHT GLASS
- 14- SELENOID VALVE
- 15-REDUCER GEAR and MOTOR
- 16- EXPENSION VALVE
- 17- EVAPORATOR DRUM
- 18- LIQUID TANK (RECEIVER)
- 19- EVAPORATION REGULATE VALVE
- 20- VIBRATION ABSORBER

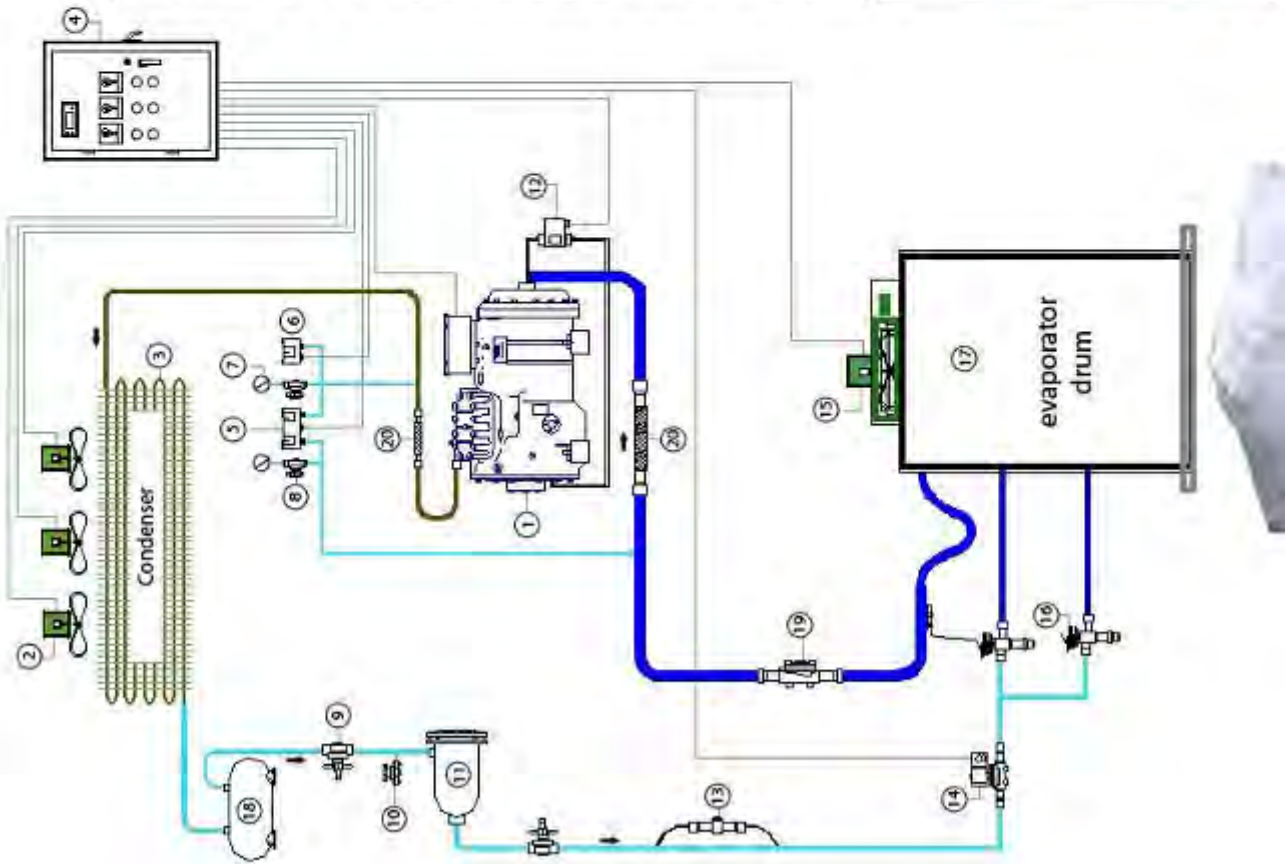

DEVICE COMPONENT

ICE EVAPORATOR

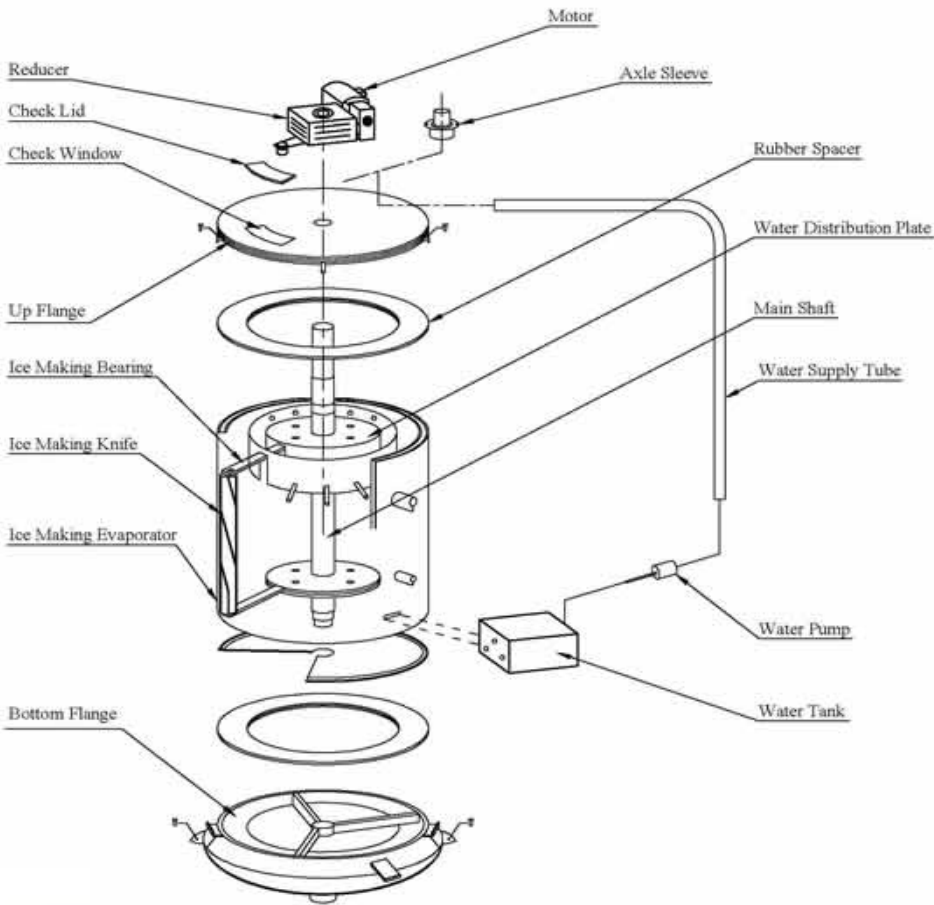

COMPRESSOR



SP-6L400E

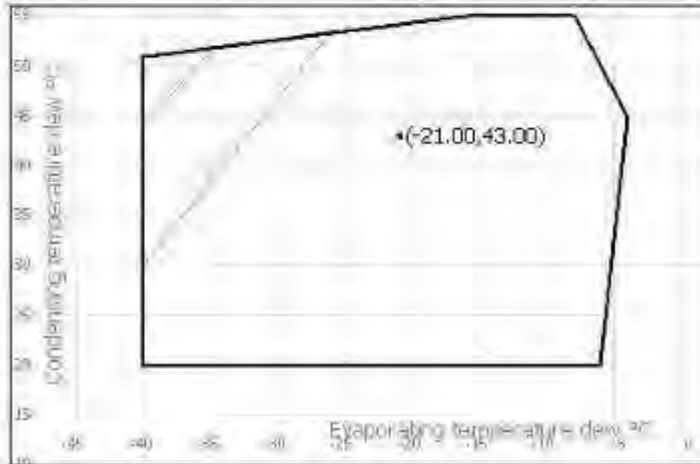

Project Condition

Refrigerant	R404A
Evaporating Temperature	-21,00 °C
Evaporating Pressure	2,89 bar abs
Condensing Temperature	43,00 °C
Condensing Pressure	19,50 bar abs
Suction gas superheat	10 K
Liquid subcooling	5 K

Output data

Cooling capacity	49,5 kW
Input power	28,0 kW
COP	1,768
Absorbed Current	48,4 A
Condenser capacity	77,6 kW
Evaporator mass flow rate	1660,6 kg/h
EER	6,032
Oil cooling power	0 kW
Discharge temperature	- °C
Initial injection pressure	- bar

Technical data

Displacement at 50/60 Hz [m³/h]	154,4 / 185,3
Nº of cylinders	6
Weight [Kg]	247
Oil Charge [dm³]	4,2
Discharge connection int.Ø [mm/inch]	42/ 1 5/8"
Suction connection int. Ø [mm/inch]	54/ 2 1/8"
Motor	400/3/50
Lra[A]	201/330
Fla[A]	75

CONDENSER

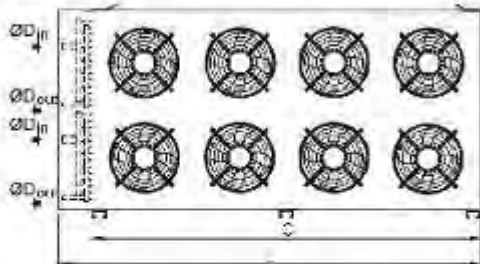

Dimensions (mm)

L = 3500	
H = -	
W = 1675	
A = -	
B = -	
C = 3300	
D = -	
E = 360	
G = -	
K = 915	
	ØDin = 2x42
	ØDout = 2x35

Capacity	194050 W
Fluid	R404A
Air Flow	56610 m3/h
Altitude	0 m
Atm	1.013 bar

Coil	
Heat Transfer Surface	391.40 m2
Tube Volume	75.4 dm3
Fin Pitch	2.5 mm

Tube Material	Copper
Fin Material	Aluminum
Casing Material	Electrostatic Powder Painted G.S. (RAL 7044)
Weight	450 kg

Conditions

Air Inlet Temperature	25 °C
Fluid Inlet Temperature	40 °C

Fans

Diameter	Ø500 mm
Number	2 x 4 adet
Supply	230 V
	50 Hz
Power (Total)	8160 W
Current (Total)	27.2 A
Speed	1210d/d
Energy Efficiency Class (At standart rating condition)	D

Sound Pressure Level (LpA)	55 dBA
Sound Power Level (LwA)	87 dBA
Distance	10 m

DEVICE COMPONENT

SCHEMATIC WIEW

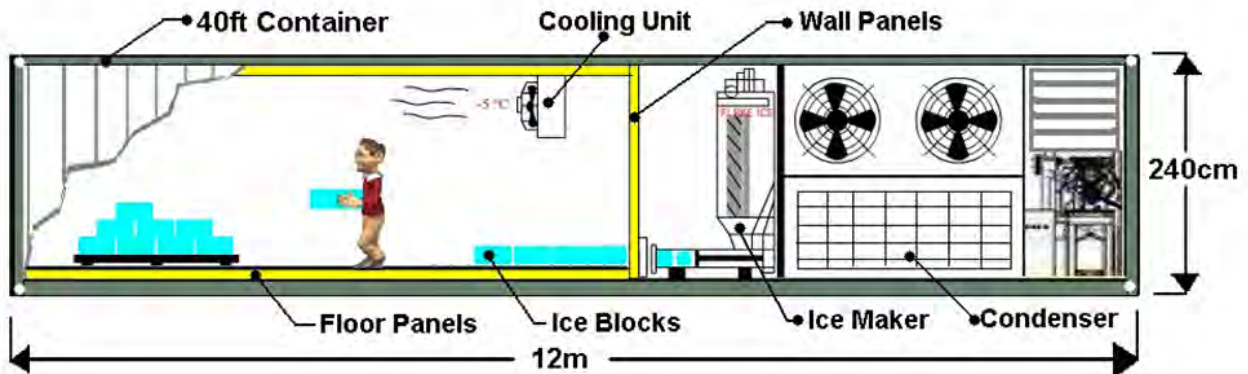

HYDROLIC ENGINE



RATINGS AND PERFORMANCE

4 pole, 1500 min⁻¹

Speed, Power Factor, Efficiency, Locked rotor current and Torque values are quoted at 400V, 50 Hz

3-phase, 400 V, 50 Hz (Eurovolt)
 Duty type : S1 (continuous)
 Degree of protection : IP 55 (TEFC)
 Insulation class : F (105K)
 Temp. Rise : Class B (80K)



Rated output	Type	Full-load data					Starting data				Breakdown torque ratio M_v/M_q	Moment of inertia J	Weight approx. kg			
		Speed n	Current I_n			Torque M_v	Power factor $\cos \phi$	Locked-rotor current ratio I_r/I_n		Locked-rotor torque ratio M_r/M_q						
			A					%								
kW		min ⁻¹	At 360V	At 400V	At 415V	Nm		At 4/4	At 3/4	D.O.L.	YΔ	D.O.L.	YΔ	kgm ²	kg	
7.5	AGM 132 M 4	1430	15.8	15.3	15	50	0.80	37.4	87.2	8.0	1.9	2.5	0.81	2.5	0.026	47

DEVICE COMPONENT

Technical Specifications:

System process is like as you can see in the project this picture. It is consisting from 1 compact unit, it runs by putting one above the other and after electricity and water connections are constructed.

CONTAINER SPECIFICATIONS

Panels: The panels are produced with a sand-wich press system consisting 40kg/m³ density polyurethane between polyester painted galvanized steel material that does not faint or become lusterless or does not require re-painting and that is highly resistant to external factors and chemical agents.

Floor: The floor is produced with a sandwich press system consisting of water resistant plywood, en dried special wooden supports and polyurethane sandwiched between steel material.

Exterior			Door Opening																										
Length	Width	Height																											
40'-0"	8'-0"	8'-6"	<table border="1" style="width: 100%; border-collapse: collapse; text-align: center;"> <tr style="background-color: #92D050;"> <th>MGW</th> <th>TARE</th> <th>NET</th> <th>Width</th> <th>Height</th> </tr> <tr> <td>67,200 lb</td> <td>8,820 lb</td> <td>58,380 lb</td> <td>7'-8 1/8"</td> <td>7'-5 3/4"</td> </tr> <tr> <td>12.192 m</td> <td>2.433 m</td> <td>2.591 m</td> <td>2.343 m</td> <td>2.280 m</td> </tr> <tr style="background-color: #92D050;"> <th colspan="3">Weight</th> <th>CU.M</th> <th>CU.FT</th> </tr> <tr> <td>30,480 kg</td> <td>4,000 kg</td> <td>26,480 kg</td> <td>67.5</td> <td>2,385</td> </tr> </table>		MGW	TARE	NET	Width	Height	67,200 lb	8,820 lb	58,380 lb	7'-8 1/8"	7'-5 3/4"	12.192 m	2.433 m	2.591 m	2.343 m	2.280 m	Weight			CU.M	CU.FT	30,480 kg	4,000 kg	26,480 kg	67.5	2,385
MGW	TARE	NET			Width	Height																							
67,200 lb	8,820 lb	58,380 lb	7'-8 1/8"	7'-5 3/4"																									
12.192 m	2.433 m	2.591 m	2.343 m	2.280 m																									
Weight			CU.M	CU.FT																									
30,480 kg	4,000 kg	26,480 kg	67.5	2,385																									
Interior																													
Length	Width	Height																											
39'-5 45/64"	7'-8 19/32"	7'-9 57/64"	<table border="1" style="width: 100%; border-collapse: collapse; text-align: center;"> <tr style="background-color: #92D050;"> <th colspan="5">Purpose</th> </tr> </table>		Purpose																								
Purpose																													
12.032 m	2.352 m	2.385 m																											

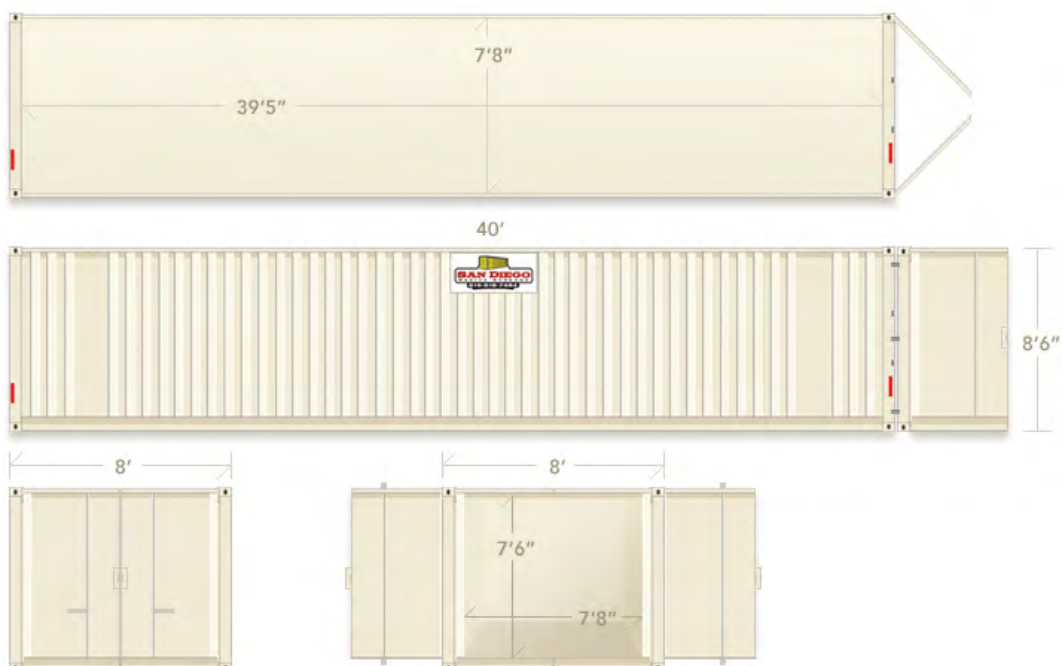

DEVICE COMPONENT

Compressor: Possession of easy to find spare parts, easy troubleshooting and fault correction, easy installation and demounting and correctly timed maintenance makes a compressor that is preferred over others. For this reason compressors are an area that our company has made major investments in the manufacturing machine park and spare parts and has extensive accumulated experience.

Condenser: Condenser is cooled by ventilation. This equipment consists of rigid aluminum lamels and copper pipes that pass between them. The lamels have been fixed by widening the copper pipes.

Hydraulic Motor: Hydraulic motor is a component that transforms mechanical energy to hydraulic energy. Taking its rotational movement from the electric motor, it sucks the fluid from the tank by the principle of extension and retraction force and feeds into the system.

Main Piston: This component takes the energy from the motor and transforms it into mechanical energy.

Control Panel: The device is controlled via a control system and its digital screen can be used to control the dimensions of the ice mold.

Liquid Tank: This unit gathers and stores the coolant from the system, compensates for fluctuations in the system and also acts as a buffer to prevent the entry of gas into the liquid line.

Global Valve: This facilitates the accumulation of the fluid to the battery and liquid tank during the maintenance and repair situations. The tappet on the valve ensures safe discharge of gas to the system.

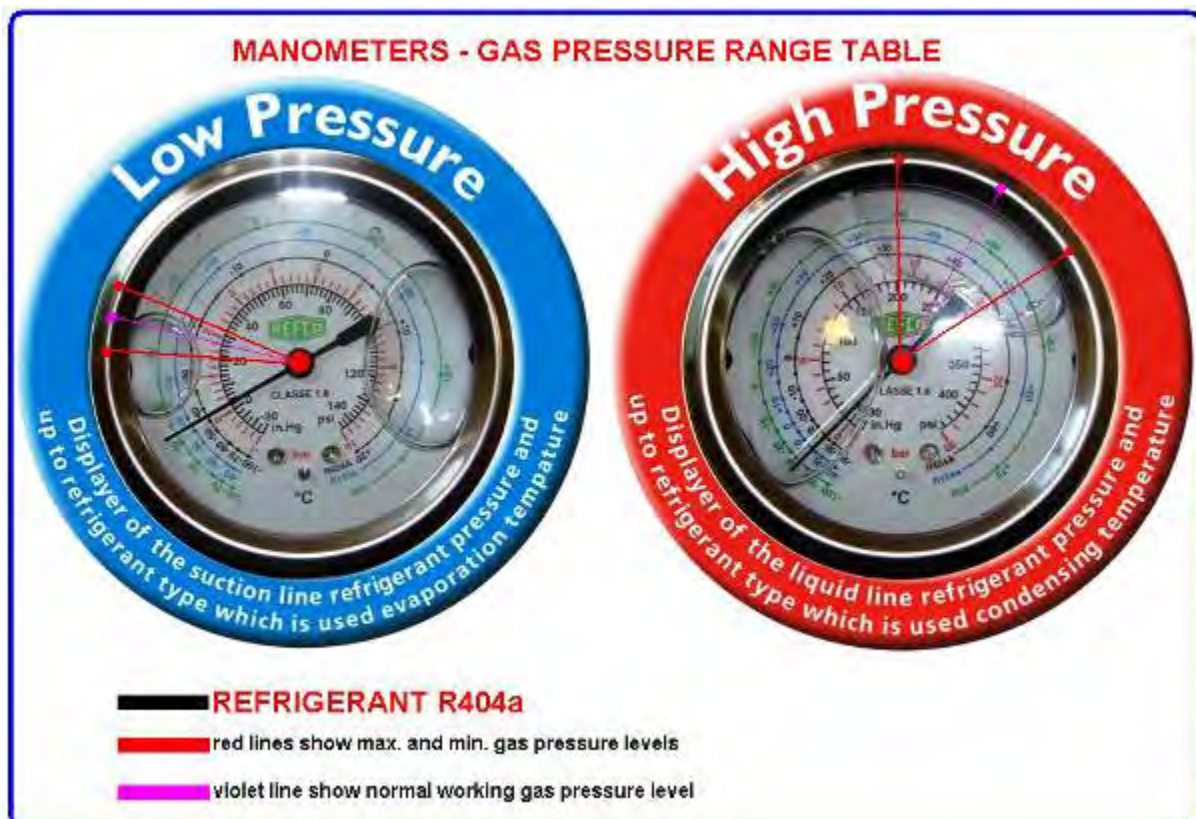

DEVICE COMPONENT

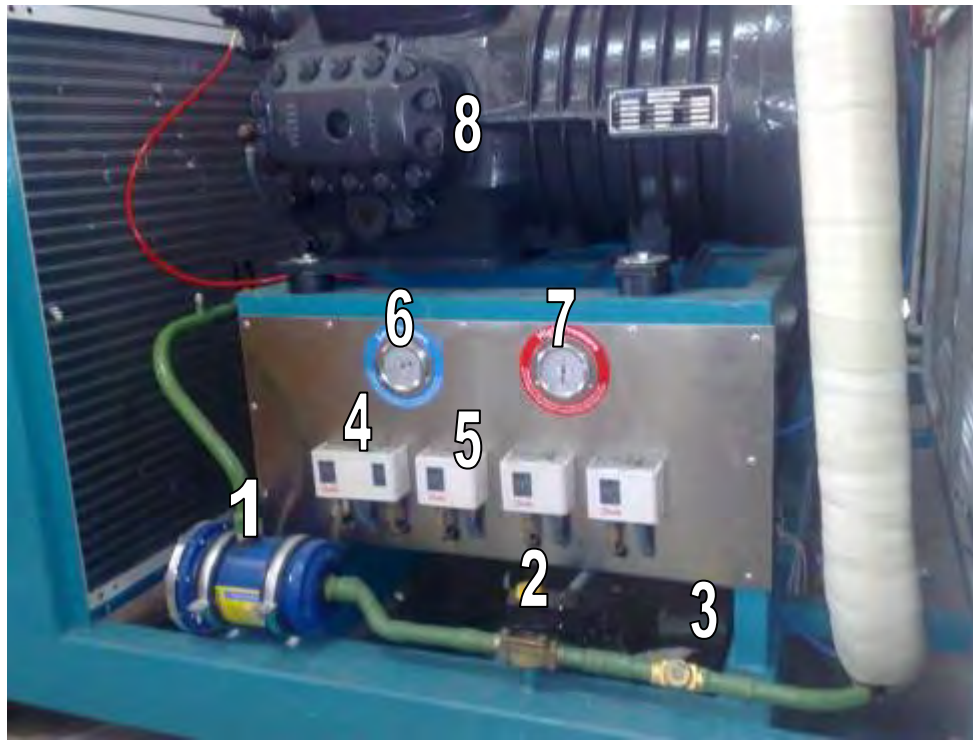

- 1- **Dryer (Drying filter):** This component filters out dust and humidity.
- 2- **Solenoid Valve:** This controls the flow of the cooling fluid from the cooling system by means of electrical signals. Valves are manufactured in either open or closed position and a magnetic field produced by an electrical signal reverses their position.
- 3- **Observation glass:** This is a component used to determine the level of the cooling fluid in the cooling system, to control the humidity in the cooling fluid and to obtain information on the cooling fluid charge level.
- 4- **AYB:** This is the low-high pressure pressurestat. This cuts out the system when the pressure drops or rises.
- 5- **KP5:** It is used to control the fan in the system. This controls the working of the fan in accordance with the high pressure, and temperature.
- 6- **Low pressure manometer:** This shows the rotation temperature in the system in accordance with the gas type.
- 7- **High pressure manometer:** This shows the going temperature in the system in accordance with the gas type
- 8- **Compressor:** This is a Mechanical device that increases the pressure of a gas by reducing its volume

DEVICE INSTALLATION

WARNING! Installation and electrical connections should only be carried out by authorized personnel.

IMPORTANT NOTES BEFORE STARTING THE INSTALLATION

- The system installer is responsible for the compliance of existing installation and security information with the applicable standards and regulations.
- Care should be taken that the products technical specifications are in accordance with the desired working conditions.
- Install the device in a well ventilated area away from heat sources.
- The product has been designed to work in a fixed position.
- In order to easily control the device, install in an accessible position.
- In order to ensure productive operation of the device, good ventilation must be provided. Thus the device must be installed so as not to impede air flow.
- Air flow to the device should not be impeded and air intake should not be heated by other machines.
- Make sure the operation area is free from dangerous and explosive materials.
- Installation should be carried out taking the ice exit and the control panel positions into account.

INSTALLATION

- Care should be taken in unpacking the product and its installation and are should be taken to ensure that the exposed pipes and connection points are not damaged.
- The installation of the product should be in compliance with its design.
- The connections used in the installation should be able to support the total operating forces.
- The installation should ensure it's not affected by external vibrations.



ELECTRICAL CONNECTION

- The operational voltage of the device is 380V / 50Hz
- Earthing must be provided.
- The ends of the power cable exiting the panel and connecting to the device must be securely tightened.
- ± 10 volt fluctuations in the voltage are acceptable. The device should not be used if there are any fluctuations outside of this tolerance.



WATER CONNECTION

- The water source must be connected by an appropriate dimension hosepipe from the water source to the water in let on the machine in a secure manner.
- Water pressure should be continuous and must not drop below 1,5 bars
- The water should be clean and filtered. Do not make water connections from a tank .

THE OPERATION ON THE DEVICE

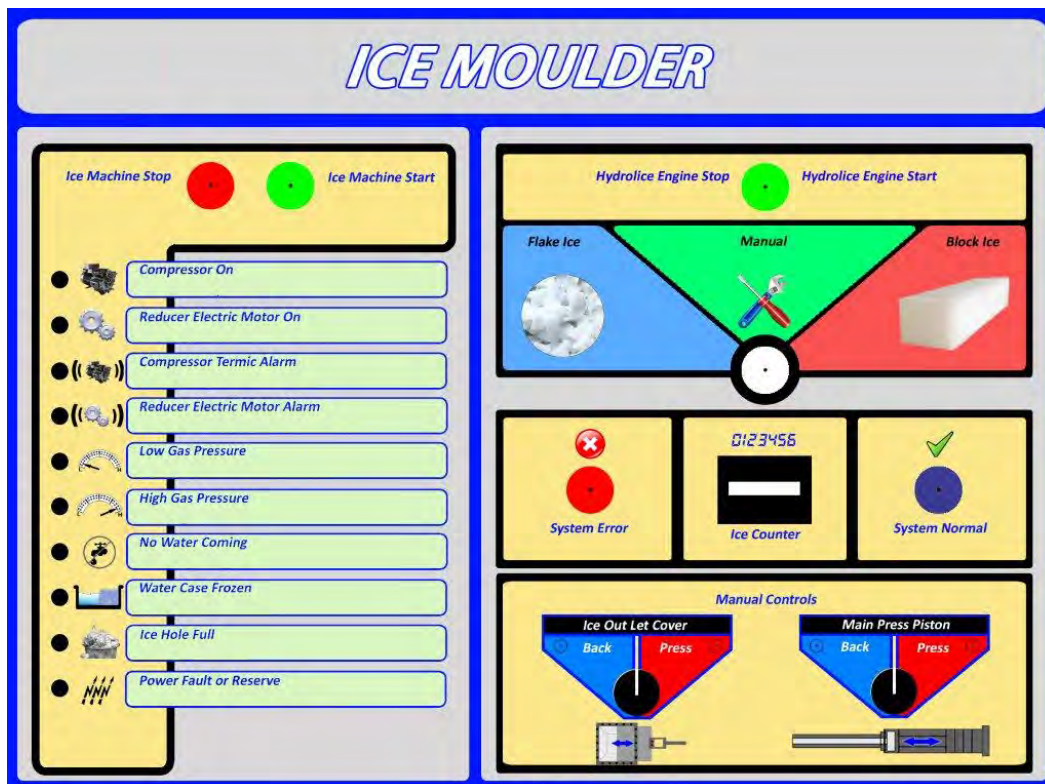

- 1- Before operating the machine, ensure that the all fan protection and grilles, accessory connections and boat lids are secure, and that the mechanical and electrical connections are correctly carried out, the electrical cables are not in the way of the fans, that the fans are unimpeded, and that the pressure settings of the pressurestat has been made .
- 2- When the fans are operating any foreign articles that may pass through the protective grill of the fans, like fabric pieces and long hair should be kept away from the area.
- 3- Control the fuses in the electrical panel.
- 4- In order to operate the hydraulic motor presses the, “Hydraulic Engine Start” button.
- 5- Select the desired ice type (flake ice or block ice). Manual selection should be used only in maintenance and repair situations.
- 6- Ensure that the “System Normal” light is on.
- 7- Before operating the ice machine make sure that the hydraulic components are in working order.
- 8- To operate the ice machine presses the “Ice Machine Start” button.
- 9- The system will automatically cut in.
- 10- After an initial period has passed control the dimensions of the ice bocks you have specified. Adjust to the desired dimension. You cannot make ice blocks longer than 50 cm.
- 11- If abnormal operating conditions such as excessive sound is detected, the system should be halted, and the supplies should be consulted. Excessive vibrations from the products fan and compressor may make the device inoperable.
- 12- When the device is in operation one or more should be present at all times, do not leave the device unattended during operation .

TURNING OFF THE DEVICE

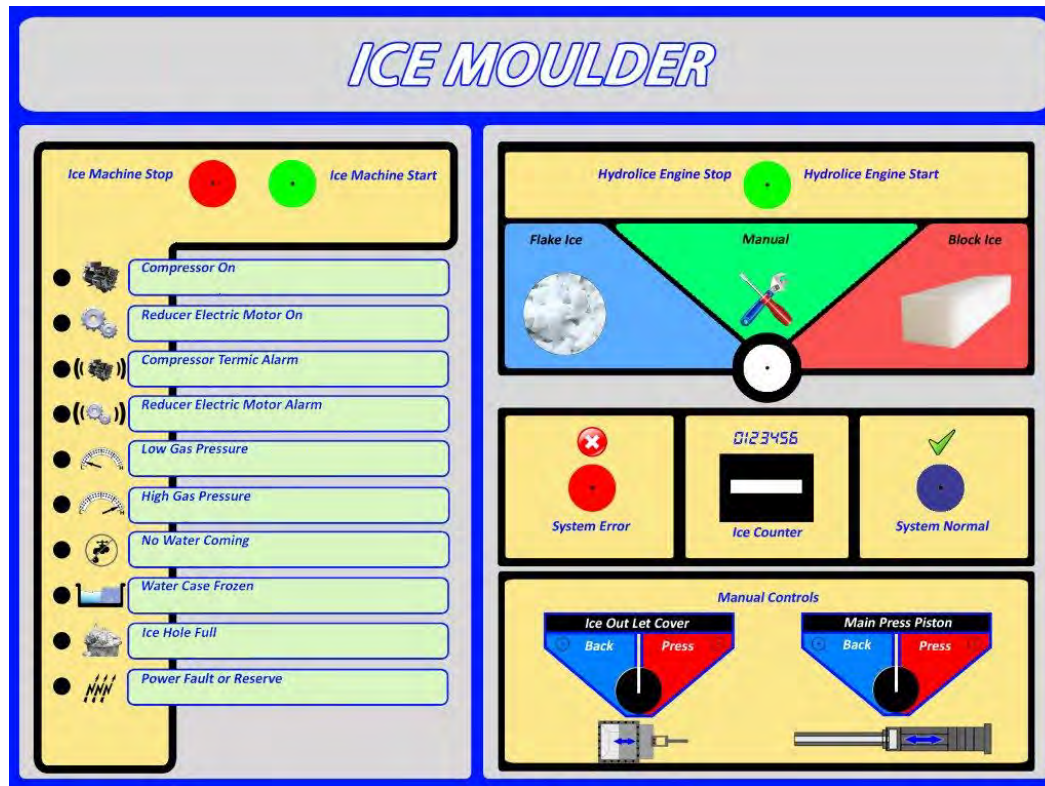

- 1- To stop the ice machine press the "Ice Machine Stop" button.
- 2- Wait for the hydraulic piston to discharge the remaining ice blocks in the system
- 3- To stop the hydraulic motor press the "Hydraulic Engine Stop" button.
- 4- If the device is to be out of service for an extended period of time turn off the fuses .
- 5- The shutting from the fuse box is suggested because if the gas pressure increases in the machine, the machine automatically cuts in and releases the pressure, this is a normal procedure.

ADJUSTING THE ICE MOLD DIMENSIONS

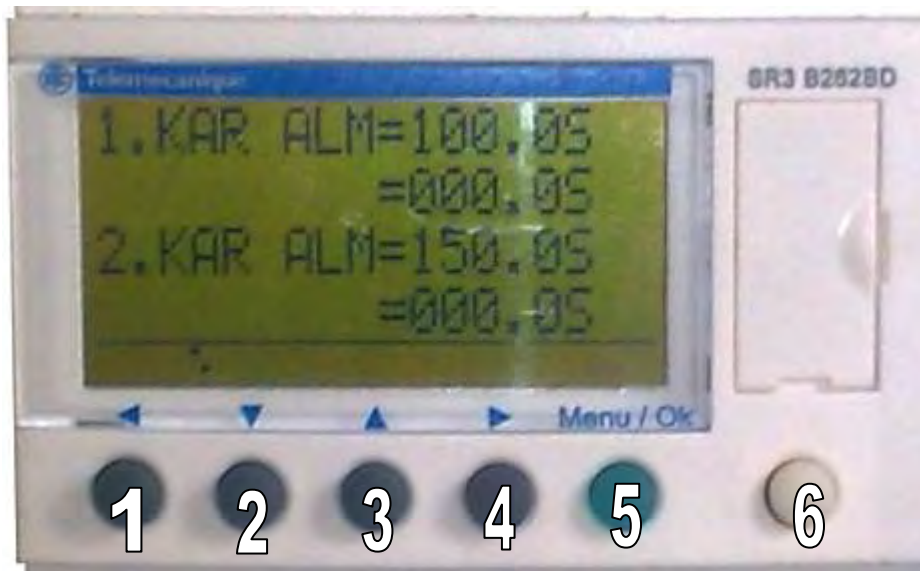

- First press button number 6 then button 4. Take away your hand.
- When you see the 1. KAR ALM= writing flashing press button no 4 and make sure the 2KAR ALM= writing is flashing also
- In order to set the value of the 2.KAR ALM= use buttons 2 and 3 to extend or reduce the snow acquisition period.
- After adjusting the snow acquisition period press button 5 to end the sequence of operations. .

Note: As Snow acquisition values increase the ice molds length will increase. Please ensure that the snow acquisition periods do not exceed the minimum of 110 and a maximum 175 values. Any other values outside of this range may damage the machine. Do not adjust the 1.KAR ALM= value.

OPERATING PRINCIPLES

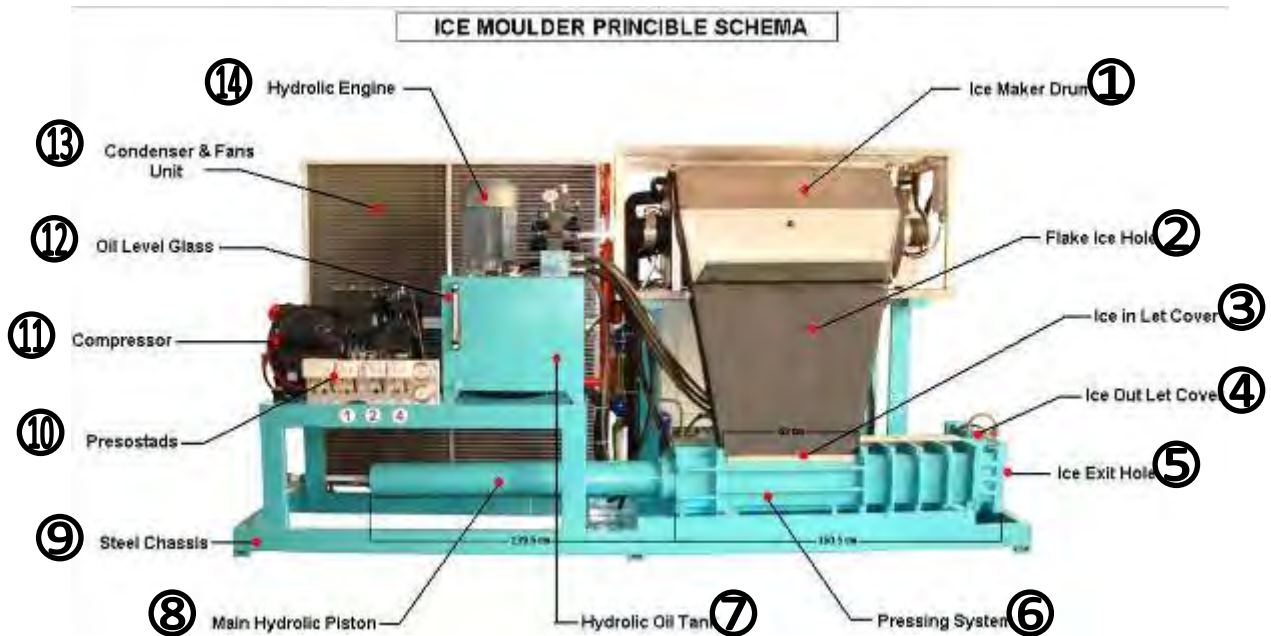

The compressed gas in the Compressor (11) enters the condenser (13) at high pressure and heat. It condenses here and its heat is reduced by the fans and goes to the expansion valve. At the expansion valve the pressure of the gas is reduced and in the ice maker drum (1) the gas evaporates and starts to make ice. The ice flakes that are formed drop down from the, flake ice hold (2), and starts to accumulate in the pressing system (6). In order to close the ice in let cover(3) the hydraulic engine(14), takes the oil from the hydraulic oil tank(7) and sends this to the, ice in let cover(3) thus ensuring its closing. The main hydraulic piston (8) in its first compression ensures that the ice are swept forward. After the first compression/sweep operation, the second compression cycle starts. The same processing continues, but this time the ice mass is pressed and becomes a block. This compression is carried out under 100 bar pressure. After the second compression the ice out let cover (4) is opened. The main hydraulic piston (8) starts to move, with the oil it receives from the hydraulic engine (14), in order to evacuate the ice from the ice exit hold (5) .

OPERATING, MAINTENANCE AND REPAIR INSTRUCTIONS

Warning! All electrical connections must be disconnected before maintenance and repair work .

- 1- Ensure (380V/50Hz) energy is available.
- 2- Make sure continuous water pressure of 1,5 bar is available, do not make connection to a water tank.
- 3- Make sure the power cable is connected by a qualified electrician and has a cut off switch installed as well.
- 4- Neutral and earth connections must be made.
- 5- Make sure the sequence of the phases is correct.
- 6- Carry out the water supply connection making sure that it is clean and filtered.
- 7- Do not supply water higher than 28°C, if above this temperature then the machine capacity will suffer. In order to increase your capacity you can first pass your water supply through a water cooler system.
- 8- Ensure the ice evacuation line is unimpeded.
- 9- Visually control the production of ice; machine must not be left unattended at any time.
- 10- As the machine can produce ice continuously, it must be attended by a trained person at all times.
- 11- Do not stick limbs or fingers into the ice hold, when the machine is in operation.
- 12- Always and at all times control that the condenser container is clean. If necessary clean without damaging the surfaces.
- 13- Periodically control the gas passage observation porthole, if there is foam or a reduction in the level of gas, please inform the supplier.
- 14- If there is unusual and excessive noise from the machine, stop operating and inform the supplier.
- 15- Do not interfere in the machine settings, do not allow unqualified people to intervene.
- 16- Do not keep changing the switches in order to show to someone.
- 17- The machine should not be handled by any personnel other than those authorized by Termodizayn.
- 18- Ensure that the machine operator is trained by the supplier.
- 19- The maintenance and repair of the product should be carried out only by authorized personnel.
- 20- Please comply with all security and personnel rules when carrying out maintenance and repair.
- 21- When carrying out maintenance and repair, care should be taken that the fluid circulation has been halted and power from the machine has been disconnected.
- 22- If any of the pipes or connection pipes of the product need to be replaced or repaired then all fluid must be drained off.
- 23- Make sure that no foreign objects or tools have been left in or around the product after maintenance and repair work.

PERIODIC CONTROLS (2-4 times a month)

- Controls should be carried out to ensure there is no dust on the lamel surfaces that can obstruct the flow of. If necessary these should be cleaned using a brush, pressurized air and hot water.
- Care should be taken to prevent damage to lamels and the fans. Chemicals that can cause reactions to the product should be avoided. The electrical connections and fan motors should not be in contact with water during cleaning.
- The mechanical and electrical connections of the fans should be controlled. Fans should be able operate freely. The protective grills must be intact.
- The pipelines should be controlled for leaks and damage.
- All connections should be checked, specially the fan motor assembly connections and the product assembly connections.

TROUBLESHOOTING

SYSTEM DOESN'T WORK?

- The device start button isn't pressed. Check that it's been pressed.
- Voltages are fluctuating out of range. Do not operate the machine when voltage fluctuations above ± 10 volt occur. If necessary use a voltage regulator for continuous operation.
- One or more of the phases from the main power supply may be out of action. Control the main power cables.

COMPRESSOR IS WORKING CONTINUOUSLY?

- Systems gas is insufficient. Get it serviced.
- One of the main power phases or the compressors contactor contacts have stuck. Change the faulty contactor. Control the voltages.
- The low pressure adjustment of the pressurestat is set too low. Set the low pressure cut off value to 1.0 bar and difference to 0.7b bar

COMPRESSOR ISN'T WORKING?

- The device fuse is shut or electric supply isn't getting through. Control the power supply and the fuses.
- Compressor thermostat is blown.
 - 1- Control the compressor temperature. If overheated wait for it to cool.
 - 2- Control the electrical connections.
 - 3- Make sure the fans are working properly. After the problem has been resolved, press the reset button of the thermostat and restart the machine.
- High pressure o pressurestat has cut off the connection.
 - 1- Control the condenser grills, if dirty then clean. If the condenser unit is in a closed environment ensure proper air circulation exists.
 - 2- Control the condenser fans for correct operation. If you can resolve the problem then press the reset button of the "High Pressure Pressurestat" and restart the machine. Else call for service.

TROUBLESHOOTING

COMPRESSOR IS WORKING INTERMITTENTLY?

- The low pressure adjustment of the pressurestat is set too high. Set the low pressure cut off value to 1.0 bar and difference to 0.7b bar.
- Evaporator fan motors aren't working. Find the reason and fix.
- Solenoid valve connection cable is loose. Tighten the cable.
- A pipe in the system is damaged. Control and ask for service if necessary.

NO ICE ?

- Systems gas has been reduced. Call for service.
- The ice container may be full or blocked, in this situation the ice doesn't fall down, shut the machine down and wash the area where the ice falls with warm water to melt the ice. This occurs when the second adjustment is set too high, reduce the 2.KAR ALM= duration.

ABNORMAL NOISES FROM THE HYDRAULIC MOTOR?

- There may be a problem with the photocells on the system, control the operation of the eyes. The eye sensors have signaling lamps on them, you tell the status of the eyes from these lamps.
- Reset the system by cutting off power and restarting .

APPLICATION SAMPLES

