

Block Ice Machine

MBI-3000

COMPRESSOR



BLOCK ICE MACHINE



MOLD TYPE

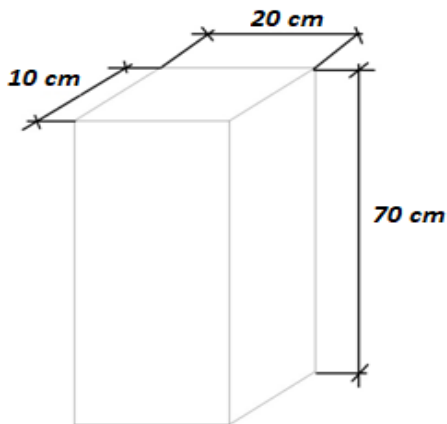

| | |
|------------------------------|---------------------|
| Unit Code | MBI-3000 |
| Cooling Capacity | 23700 watt |
| Ice Production (24h) | 3.000 kg |
| Block Ice Capacity (Per Day) | 252 pieces |
| One Shift Ice Capacity | 1000 Kg / 84 pieces |
| One Shift Time | 7 Hours |
| Block Ice Size | 20 x 10 x 70 cm |
| Block Weight | 12 Kg |
| Compressor Type | Semi Hermetic |
| Compersor Displacement | 64,7 cm3 |
| Compressor Brand | RefComp |
| Compressor Power | 15 HP |
| Compressor Power Input | 12,2 kw/h |
| Compressor Current | 22,8 Amper |
| Compressor COP | 1,94 |
| Evaporator Type | Mold Type |
| Evaporation Temp. | -18°C |
| Condenser Surface | 142 m2 |
| Condenser Air Flow | 36.000 m3/h |
| Condenser Fans | 4x500mm |
| Refrigerant | R-404a |
| Mixer Motor Power | 0,55 kw |
| Dimensions (WxLxh) | 4500x2140x1420 mm |
| Water Type | Fresh (City Water) |
| Electric Board | Include |
| Voltage | 380V / 50Hz / 3Ph |