

BLOCK ICE MACHINE

CP-5T

CAPACITY TABLE

Water inLet Temperature

Ambient Temperature	kg/day	5 C	16 C	25 C	30 C
	15 C	5.375 kg			
30 C		5.000 kg			
35 C			4.900 kg		
45 C					4.500 kg

UNIT PICTURE



EVAPORATOR BASE

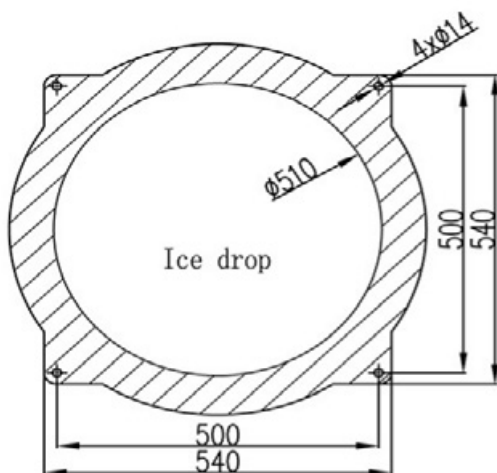

Unit Code	Block CP 5T
Cooling Capacity	33.500 watt
Ice Production (24h)	5.000 kg/24h
Block Ice Capacity (Per Day)	1000 pieces
Block Ice Capacity (Per Hour)	41 pieces
Block Size	15x15x30 cm
Block Weight	5 Kg
Compressor Type	Semi Hermetic
Compersor Displacement	102,9 m3/h
Compressor Brand	Refcomp
Compressor Power Input	17,9 kw/h
Hydrolic Engine Motor Power	3 kw/h
Compressor Current	31 Amper
Compressor COP	1,87
Evaporator Type	Vertical Drum
Evaporation Temp.	-20C / -22C
Condenser Surface	200m2
Condenser Air Flow	36.000 m3/h
Condenser Fans	4x500mm
Refrigerant	R-404a
Reductor Motor Power	0,37 kw
Total Unit Weight	2200 kg
Water Inlet	3/4"
Water Outlet (Drain)	Drain 3/4"
Water Type	Fresh (City Water)
Electric Board	Include
Voltage	380V / 50Hz / 3Ph