

Flake Ice Machine

SFM 50

CAPACITY TABLE

		Water inLet Temperature			
Ambient Temperature	kg/day	5 C	16 C	25 C	30 C
	15 C	5500 kg			
	30 C		5200 kg		
	35 C			5000kg	
	45 C				4750kg

UNIT PICTURE

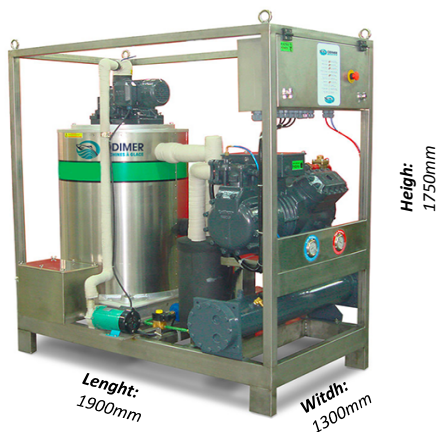

EVAPORATOR BASE

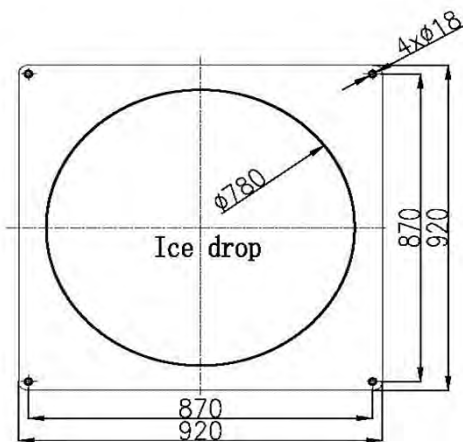

Unit Code	SFM 50
Cooling Capacity	30200 watt
Ice Production (24h)	5000.kg
Ice Production (1h)	210 kg
Ice Thickness	~ 1,8 mm.
Compressor Type	Semi Hermetic
Comperssor Displacement	129,1 m3/h
Compressor Model / Brand	SP4L300E / Refcomp
Compressor Power Input	19,1kw.
Compressor Current	33,4 Amper
Compressor COP	1,58
Evaporator Type	Vertical Drum
Evaporation Temp.	-28C
Condenser Type	Sea Water Cooled
Condenser Water Flow	18,5 m3/h
Condenser Velocity	2,49 m/s
Refrigerant	R-404a
Pump Power	0,13 Kw. 220V
Pump Water Flow	3600 lt/h 1,5mss
Reductor Motor Power	0,55 kw
Total Unit Weight	1300 kg.
Water Inlet	1/2"
Water Outlet (Drain)	Drain 1/2"
Water Type	Sea Water
Noise (within 3m)	~78 dBA
Electric Board	Include
Voltage	380V / 50Hz / 3Ph