

Flake Ice Machine

SFM 30

CAPACITY TABLE

		Water inLet Temperature			
Ambient Temperature	kg/day	5 C	16 C	25 C	30 C
	15 C	3400 kg			
	30 C		3100 kg		
	35 C			3000 kg	
	45 C				2850 kg

UNIT PICTURE

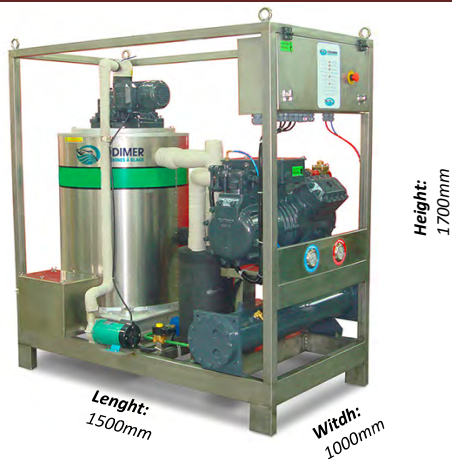

EVAPORATOR BASE

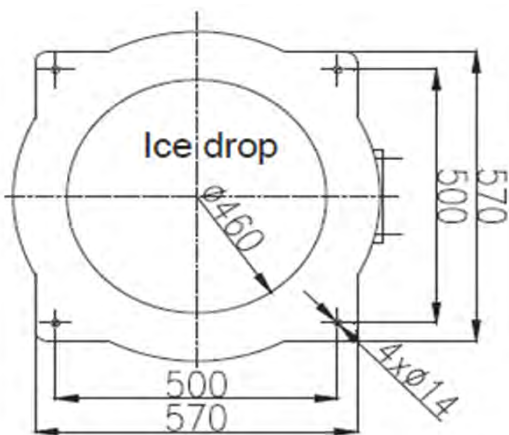

Unit Code	SFM 30
Cooling Capacity	18.000 watt
Ice Production (24h)	3.000 kg.
Ice Production (1h)	125 kg.
Ice Thickness	~ 1,8 mm.
Compressor Type	Semi Hermetic
Compersor Displacement	75 m3/h
Compressor Model / Brand	SP4L220E / Refcomp
Compressor Power Input	9,5 kw.
Compressor Current	21 Amper
Compressor COP	1,67
Evaporator Type	Vertical Drum
Evaporation Temp.	-28C
Condenser Type	Sea Water Cooled
Condenser Water Flow	11,2 m3/h
Condenser Velocity	2,49 m/s
Refrigerant	R-404a
Pump Power	0,03 Kw. 220V
Pump Water Flow	400 lt/h 1,5mss
Reductor Motor Power	0,37 kw
Total Unit Weight	690 kg.
Water Inlet	1/2"
Water Outlet (Drain)	Drain 1/2"
Water Type	Sea Water
Noise (within 3m)	~78 dBA
Electric Board	Include
Voltage	380V / 50Hz / 3Ph