

Flake Ice Machine

F80B

CAPACITY TABLE

Water inLet Temperature

Ambient Temperature	kg/day	5 C	16 C	25 C	30 C
	15 C	8.400 kg			
30 C		8.000 kg			
35 C				7.800 kg	
45 C					7.600 kg

UNIT PICTURE



EVAPORATOR BASE

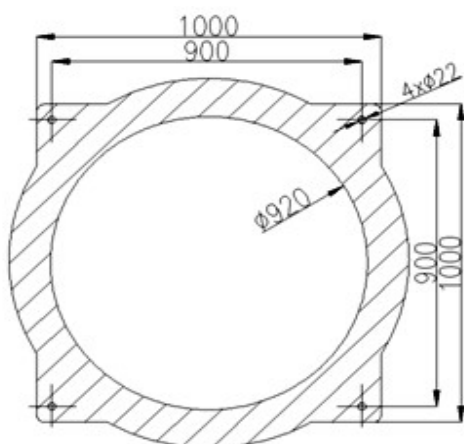

Unit Code	F80B
Cooling Capacity	47.200 watt
Ice Production (24h)	8.000 kg.
Ice Production (1h)	334 kg.
Ice Thickness	~ 1,8 mm.
Compressor Type	Semi Hermetic
Compressor Displacement	154,4 m3/h
Compressor Brand	Frascold/Dorin
Compressor Power Input	27,24 kw.
Compressor Current	48,98 Amper
Compressor COP	1,58
Evaporator Type	Vertical Drum
Evaporation Temp.	-20C / -22C
Condenser Surface	400m2
Condenser Air Flow	72.000 m3/h
Condenser Fans	8x500mm
Refrigerant	R-404a
Pump Power	0,25 Kw. 380V
Pump Water Flow	1200 lt/h 2mss
Reductor Motor Power	0,75 kw
Total Unit Weight	2170 kg.
Water Inlet	3/4"
Water Outlet (Drain)	Drain 3/4"
Water Type	Fresh (City Water)
Noise (within 3m)	~85 dBA
Electric Board	Include
Voltage	380V / 50Hz / 3Ph