

Flake Ice Machine F10A

CAPACITY TABLE

		Water inLet Temperature			
Ambient Temperature	kg/day	5 C	16 C	25 C	30 C
	15 C	1150 kg			
	30 C		1020 kg		
	35 C			975 kg	
	45 C				900 kg

UNIT PICTURE



EVAPORATOR BASE

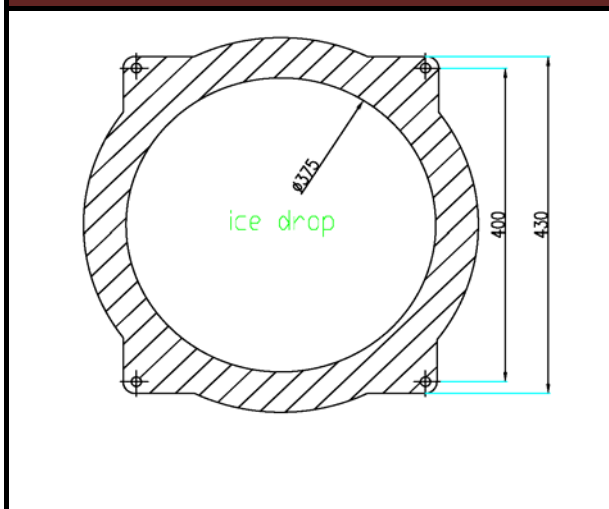

Unit Code	TD-F10A
Cooling Capacity	6800 watt
Ice Production (24h)	1.000 kg.
Ice Production (1h)	41,6 kg.
Ice Thickness	~ 1,8 mm.
Compressor Type	Semi Hermetic
Comperssor Displacement	21 m3/h
Compressor Model / Brand	SP2L040E / Refcomp
Compressor Power Input	3,4 kw.
Compressor Current	8 Amper
Compressor COP	2
Evaporator Type	Vertical Drum
Evaporation Temp.	-22C / -24C
Condenser Surface	39m2
Condenser Air Flow	6.000 m3/h
Condenser Fans	2x400mm
Refrigerant	R-404a
Pump Power	20 watt 220V
Pump Water Flow	200 lt/h 1,5mss
Reductor Motor Power	0,25 kw
Total Unit Weight	380kg.
Water Inlet	1/2"
Water Outlet (Drain)	Drain 1/2"
Water Type	Fresh (City Water)
Noise (within 3m)	~75 dBA
Electric Board	Include
Voltage	380V / 50Hz / 3Ph