

# Flake Ice Machine

## F100B

### CAPACITY TABLE

Water inLet Temperature

Ambient Temperature	kg/day	5 C	16 C	25 C	30 C
	15 C	10.750 kg			
30 C			10.000 kg		
35 C				9.800 kg	
45 C					9.000 kg

### UNIT PICTURE

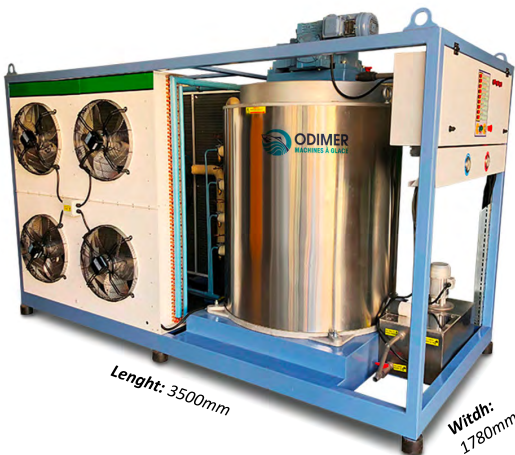

### EVAPORATOR BASE

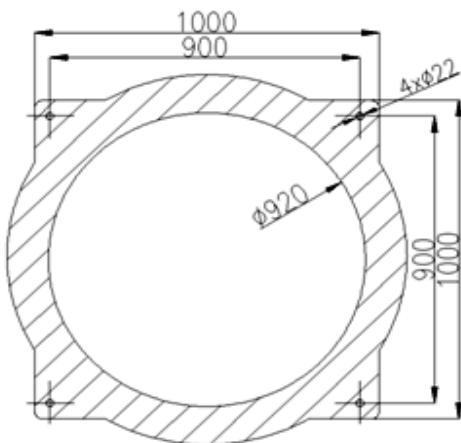

Unit Code	F100B
Cooling Capacity	56.915 watt
Ice Production (24h)	10.000 kg.
Ice Production (1h)	422 kg.
Ice Thickness	~ 1,8 mm.
Compressor Type	Semi Hermetic
Compressor Displacement	184,7 m3/h
Compressor Brand	Frascold
Compressor Power Input	32,69 kw.
Compressor Current	58,34 Amper
Compressor COP	1,74
Evaporator Type	Vertical Drum
Evaporation Temp.	-20C / -22C
Condenser Surface	400m2
Condenser Air Flow	72.000 m3/h
Condenser Fans	8x500mm
Refrigerant	R-404a
Pump Power	0,25 Kw. 380V
Pump Water Flow	1200 lt/h 2mss
Reductor Motor Power	0,75 kw
Total Unit Weight	2170 kg.
Water Inlet	3/4"
Water Outlet (Drain)	Drain 3/4"
Water Type	Fresh (City Water)
Noise (within 3m)	~85 dBA
Electric Board	Include
Voltage	380V / 50Hz / 3Ph